

Pipe Inspection Stand

for Tubehousing of ISOVOLT 160 M Series



Application

The pipe inspection stand is designed to meet the specific requirements in welding seam inspection under extreme conditions. The stand is characterized by the following possibilities of positioning:

- Swiveling of the stand around the pipe to be inspected by shifting the strap (360°)
- Rotation of the tubehousing in a clamp around its own longitudinal axis (360°)
- Rotation of the holding clamp around the stand pillar which is laterally displaced with regard to the pipe axis (360°)
- Rotation of the holding clamp around an axis at an right angle to the longitudinal tubehousing axis (360°)
- Rotation of the holding clamp around the stand pillar when displaced toward the pipe direction (360°)
- Displacement of the holding clamp, vertically to the pipe axis
- Produced under ISO 9001 certified quality management system



GE imagination at work

Technical Data

Distance focus - pipe wall	30 - 300 mm / 1.2 - 12 " (different maximum distance available upon request)
Pipe diameter, minimum	80 mm / 3.15 "
Pipe diameter, maximum	depends on the length of the strap (to be stated when ordered)
Weight	2,6 kg / 5.72 lbs

Delivery Scope

- 1 Holding clamp with rotation device and stand clamp
- 1 Stand pillar with base plate
- 1 Backing-up profile
- 1 Strap with lock

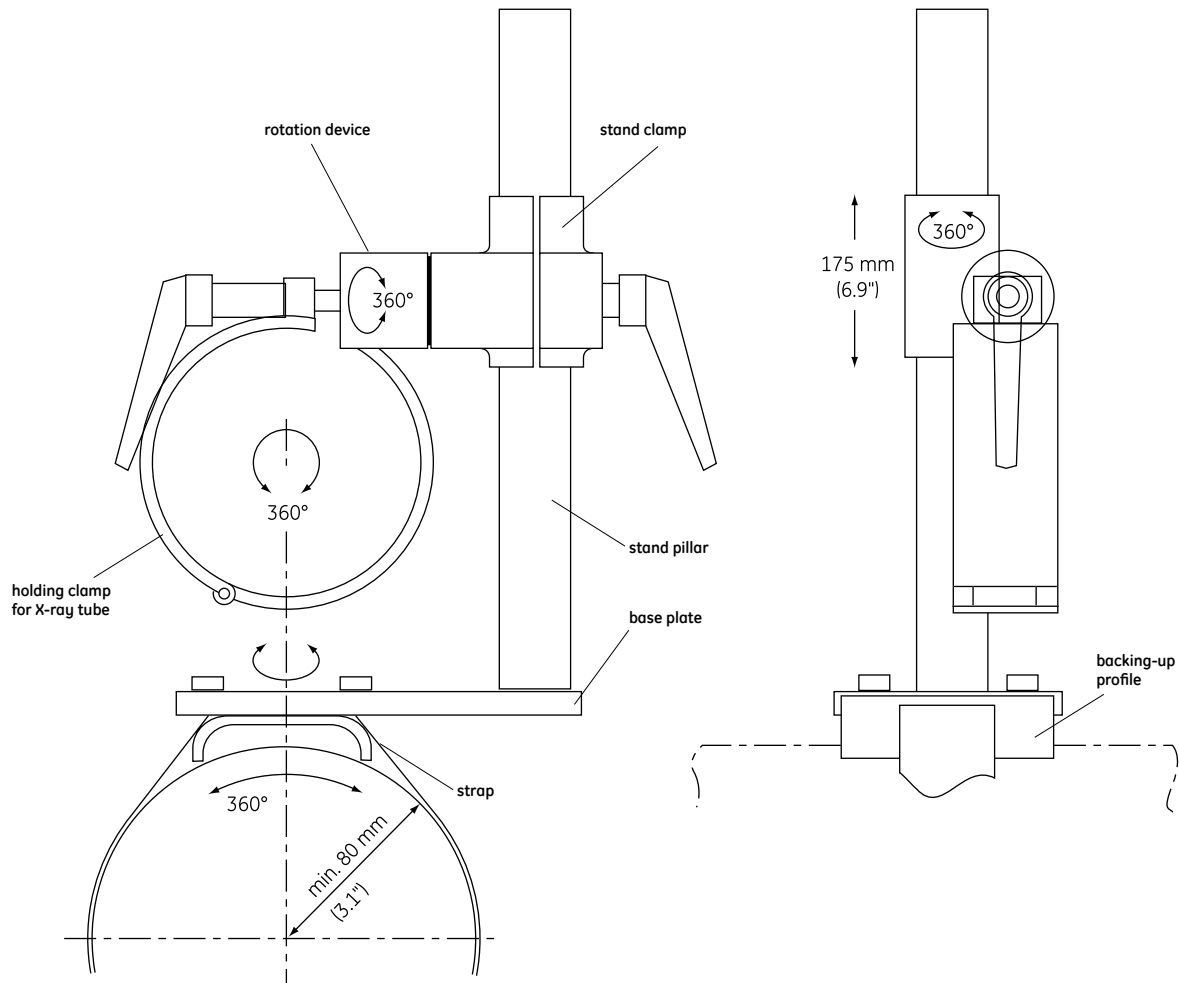

www.gesensinginspection.com

GEIT-30056EN (08/10)

© 2010 General Electric Company. All Rights Reserved. Specifications are subject to change without notice. GE is a registered trademark of General Electric Company. Other company or product names mentioned in this document may be trademarks or registered trademarks of their respective companies, which are not affiliated with GE.

Contact: GE Sensing & Inspection Technologies GmbH, Bogenstrasse 41, 22926 Ahrensburg, Germany, T +49 (0)4102 807 0